



DATA SHEET

CISCO LAND MOBILE RADIO GATEWAY

PRODUCT OVERVIEW

The Cisco® Land Mobile Radio (LMR) Gateway solution employs standard, commercially available routers with LMR-specific software capabilities. These gateways link to existing LMR systems and make the critical adaptation of LMR audio and signaling to IP. The standards-based IP network that interconnects the LMR gateways provides the intelligent services necessary for real-time, point-to-multipoint traffic. The flexible, cost-effective solution joins multiple LMR systems temporarily or permanently, and the scalable, distributed architecture can support a few to thousands of users over unlimited distances across a public or private network.

The LMR industry is moving to a packet-based network infrastructure to interconnect radio base stations. Solutions based on traditional technologies are expensive, vendor proprietary, not scalable, and unreliable during disaster scenarios, when radio communications are critical. The Cisco LMR-over-IP solution addresses this important market by enabling a scalable, robust, and secure network that integrates easily with commercially available radio systems. The core of the Cisco LMR solution consists of Cisco 2800 and 3800 Series integrated services routers, Cisco 2600XM multiservice routers, and Cisco 3700 Series multiservice access routers, which can transport LMR traffic over point-to-point or multicast voice-over-IP (VoIP) networks, enabling LMR systems to extend beyond their traditional geographic limitations imposed by transmitter signal strength.

KEY FEATURES AND BENEFITS

- **Based on open standards**—The Cisco LMR Gateway solution runs on off-the-shelf Cisco 2800, 3800, 2600XM, and 3700 series routers. Because it is based on well-known, open standards protocols such as multicast VoIP and H.323 v.2, it supports innovation and the development of value-added applications. It easily integrates with open standards applications that extend LMR communications to devices such as personal digital assistants (PDAs), PCs, IP phones, and public switched telephone networks (PSTNs).
- **Interoperable with disparate LMR networks**—With its open standards IP infrastructure, the Cisco LMR solution connects disparate, multivendor radio networks without the need for manual, dispatcher intervention.
- **Offers a cost-effective and reliable replacement for dedicated leased lines**—Running Cisco LMR communications on IP infrastructure yields cost benefits and operational efficiencies and increases the robustness of existing radio systems. Converged networks provide one highly robust and flexible infrastructure for all needs, including LMR, IP telephony, and data communications.
- **Protects investments in existing radio assets**—With Cisco LMR solutions, customers can continue to use push-to-talk (PTT), carrier-operated relay (COR), and tone-controlled radio systems by interfacing with either analog ear-and-mouth (E&M) ports or digital T1/E1 ports on Cisco multiservice access routers.
- **Offers enhanced LMR features**—The latest Cisco IOS® Software release enhances LMR features to manage tone-controlled radios, handle fluctuation in audio levels, and deal with faulty PTT buttons on the radios.
- **Enhanced network features**—The Cisco LMR solution is based on Cisco integrated service routers such as the Cisco 2800 and 3800 series routers, which run the industry-leading Cisco IOS Software. Cisco IOS Software enhances LMR networks by incorporating advanced features such as security, quality of service (QoS), IP telephony, and wireless (802.11).
- **Enhanced security and VPN features**—Cisco IOS Software provides a robust suite of security features, including Voice and Video Enabled VPN (V3PN), firewall, and intrusion detection, to LMR networks for secure communications.

PRODUCT ARCHITECTURE

Many traditional radios are keyed using the electrical leads of PTT and COR. The Cisco LMR can tunnel the digitized audio and associated signaling across the VoIP network between two radio base stations by using the Cisco IOS Connection Trunk feature to establish a virtual tie line, which replaces a leased tie line.

- The carrier-operated relay (or COR) on the radio maps to the M lead on an E&M router interface. When asserted, it causes Real-Time Transport Protocol (RTP) packets to be inserted across the QoS-enabled VoIP network to the remote Cisco LMR router or any other standards-based media server.
- Conversely, the presence of an RTP packet stream from the VoIP network causes the E-lead to be asserted on the E&M router interface, thereby asserting PTT on the radio side.

The LMR feature set comprises this function, along with thresholds and timers for tuning E- and M- lead behavior. It preserves the integrity of the electrical signaling across the VoIP network. In addition, the following enhanced Cisco IOS Software features make this interface between the radio and the router a value proposition:

- **Static tone injection**—You can configure the router to inject audio tones through the digital signal processors (DSPs) onboard for keying up or selecting the channel on the radio.
- **Notch filtering**—You can filter guard and idle tones before the audio is sent over the IP link. This helps maintain the integrity of the audio.
- **Configurable voice transmit delay**—To avoid front-end clipping, you can configure a transmit delay to make the Cisco LMR Gateway play incoming voice to the radio side with a delay of up to 1.5 seconds.
- **PTT timeout**—A faulty PTT button on a radio can severely hamper radio communication. You can configure the Cisco LMR Gateway to disable communication from a radio after a configurable PTT timeout duration.
- **Automatic gain control**—Fluctuating audio levels because of distance from the radio or disturbance in the medium can be frustrating. With automatic gain control, you can configure the audio levels on both radio and IP side to a comfortable decibel value.
- **Startup E lead off**—Traditionally the E-lead on the E&M voice card is raised when the router is in ROMMON state or reloaded. This can cause unnecessary radio key-up in the radio world. A new command has been added to turn it off in LMR mode.

Figure 1. IP-Enabled LMR Transport

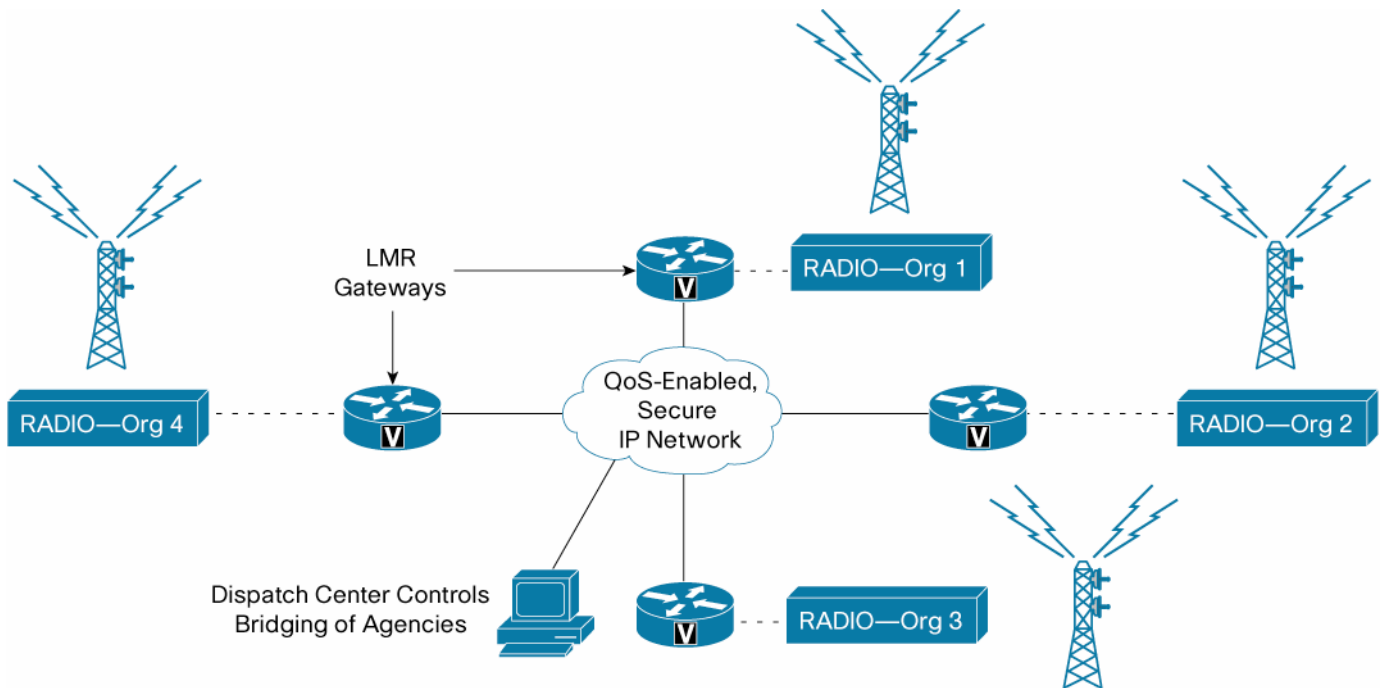

The Cisco LMR on the Cisco 2600XM, 2800, 3700, and 3800 series routers expands IP Communications between multiple radio systems by mapping E and M leads to multicast VoIP groups.

You can develop open standards-based applications to expand connectivity to IP phones and PC clients. These applications can dynamically mix RTP streams from disparate multicast VoIP groups. In addition, these applications can mix RTP streams from multiple endpoints to serve the same function as a dispatcher in traditional LMR implementations.

ORDERING INFORMATION

A feature license is required to turn on Cisco LMR Gateway functions. The feature is a configurable option or can be purchased as a spare for existing chassis.

Table 1. Ordering Information

Part Number	Price	Platforms Supported
FL-LMR	\$995.00	Cisco 2600XM, 2800, 3700, and 3800
=FL-LMR (spare)	\$995.00	Cisco 2600XM, 2800, 3700, and 3800

FEATURE AVAILABILITY

Table 2. Feature Availability

Platform	Feature Set	Minimum Flash/DRAM	Recommended Flash/DRAM
Cisco 2610XM and 2611XM	SP Services	32/128 MB	48/128 MB
Cisco 2620XM and 2621XM	SP Services	32/128 MB	48/128 MB
Cisco 2650XM and 2651XM	Advanced Enterprise Services	32/128 MB	48/128 MB
	SP Services	32/128 MB	48/128 MB
Cisco 3725	Advanced Enterprise Services	64/128 MB	64/128 MB
	SP Services	64/128 MB	64/128 MB
Cisco 3745	Advanced Enterprise Services	64/194 MB	128/256 MB
	SP Services	64/128 MB	128/256 MB
Cisco 2811, 2821, and 2851	Advanced Enterprise Services	64/128 MB	64/128 MB
	SP Services	64/128 MB	64/128 MB
Cisco 3825	Advanced Enterprise Services	64/194 MB	128/256 MB
	SP Services	64/194 MB	128/256 MB
Cisco 3845	Advanced Enterprise Services	64/194 MB	128/256 MB
	SP Services	64/194 MB	128/256 MB

PRODUCT SPECIFICATIONS

Table 3. Product Specifications

Products	Specifications
Supported Platforms	<ul style="list-style-type: none"> • Cisco 2610XM, 2611XM, 2620XM, 2621XM, 2650XM, and 2651XM • Cisco 3725, 3745, and 2811 • Cisco 2811, 2821, and 2851 • Cisco 3825 and 3845
Supported Cisco IOS Software Release	<ul style="list-style-type: none"> • 12.3(7)T SP Services and above only for Cisco 2600 and 3700 series • 12.3(11)T SP Services and above for Cisco 2600, 3700, 2800, and 3800 series • 12.4(2)T SP Services and above for LMR feature enhancements*
Protocols	Multicast VoIP, Cisco Group Management Protocol (CGMP), class of service (CoS), differentiated services code point (DSCP), H.323v2, Internet Group Management Protocol Version 3 (IGMPv3), low-latency queuing (LLQ), and type of service (ToS)
Supported Network Modules	<ul style="list-style-type: none"> • Analog: Part numbers NM-1V, NM-2V, NM-HD-1V, NM-HD-2V, and NM-HD-2VE • Digital: Part number NM-HDV (LMR feature is supported with onboard voice interface cards (VICs) on Cisco 2800 and 3800 series, requires onboard DSPs)
Supported Voice Interface Cards	<ul style="list-style-type: none"> • Analog: Part numbers VIC-2E/M (NM-1V or NM-2V only), VIC2-2E/M (NM-HD-1V, NM-HD-2V, or NM-HD-2VE only) • Digital: Part numbers VWIC-1MFT-T1, VWIC-2MFT-T1, VWIC-1MFT-E1, and VWIC-2MFT-E1 (NM-HD-2VE or NM-HDV only)

Products	Specifications
Features and Functions	Interconnect radio base stations using connection private line auto ringdown (PLAR), connection trunk and connection trunk-to-multicast VoIP networks; adjustable E lead, M lead parameters to control receive and transmit for COR and PTT radio systems

* **Feature Enhancements with Cisco IOS Software Release 12.4(2)T:** Static tone injection, automatic gain/attenuation control, configurable audio transmit delay, notch filtering, and PTT timeout.

SYSTEM CAPACITY

Table 4. Maximum LMR Ports

Platform	Maximum Analog Ports	Maximum Digital Channels
Cisco 2610XM, 2611XM, and 2620XM, 2621XM, 2650XM, and 2651XM	4	4 T1s/96 channels
Cisco 3725	8	8 T1s/192 channels
Cisco 3745	16	16 T1s/384 channels
Cisco 2811, 2821, and 2851	<ul style="list-style-type: none"> • 4 on network module • 6 on board • 10 total 	<ul style="list-style-type: none"> • 4 T1s on network module • 6 T1s on board • 10 total
Cisco 3825	<ul style="list-style-type: none"> • 8 on network modules • 8 onboard • 16 total 	<ul style="list-style-type: none"> • 8 T1s on network module • 8 T1s onboard • 16 total
Cisco 3845	<ul style="list-style-type: none"> • 16 on network modules • 8 onboard • 24 total 	<ul style="list-style-type: none"> • 16 T1s on network module • 8 T1s onboard • 24 total

SUMMARY

Cisco Land Mobile Radio (LMR) Gateway is a Cisco IOS Software-based solution that runs on Cisco 2600XM, 3700, 2800, and 3800 series access routers to integrate different radio systems over a highly scalable, robust, and secure VoIP network. The Cisco LMR solution is built on standard protocols such as multicast VoIP to integrate transparently with third-party applications to extend LMR communications to IP telephony, PSTNs, and PC-based endpoints.

ADDITIONAL INFORMATION

Contact your local or regional Cisco account representative for additional information about Cisco LMR.

TO DOWNLOAD THE SOFTWARE

To download Cisco IOS Software, visit the Cisco Software Center at:

http://www.cisco.com/en/US/products/sw/iosswrel/products_ios_cisco_ios_software_category_home.html

SERVICE AND SUPPORT

Cisco Systems® offers a wide range of services programs to accelerate customer success. These innovative services programs are delivered through a unique combination of people, processes, tools, and partners, resulting in high levels of customer satisfaction. Cisco services help you protect your network investment, optimize network operations, and prepare your network for new applications to extend network intelligence and the power of your business. For more information about Cisco Services, visit Cisco Technical Support Services at <http://www.cisco.com/en/US/support/index.html> or Cisco Advanced Services at <http://www.cisco.com/go/services>.

FOR MORE INFORMATION

For more information about Cisco LMR over IP, contact your local Cisco account representative.



Corporate Headquarters

Cisco Systems, Inc.
170 West Tasman Drive
San Jose, CA 95134-1706
USA
www.cisco.com
Tel: 408 526-4000
800 553-NETS (6387)
Fax: 408 526-4100

European Headquarters

Cisco Systems International BV
Haarlerbergpark
Haarlerbergweg 13-19
1101 CH Amsterdam
The Netherlands
www-europe.cisco.com
Tel: 31 0 20 357 1000
Fax: 31 0 20 357 1100

Americas Headquarters

Cisco Systems, Inc.
170 West Tasman Drive
San Jose, CA 95134-1706
USA
www.cisco.com
Tel: 408 526-7660
Fax: 408 527-0883

Asia Pacific Headquarters

Cisco Systems, Inc.
168 Robinson Road
#28-01 Capital Tower
Singapore 068912
www.cisco.com
Tel: +65 6317 7777
Fax: +65 6317 7799

Cisco Systems has more than 200 offices in the following countries and regions. Addresses, phone numbers, and fax numbers are listed on the Cisco Website at www.cisco.com/go/offices.

Argentina • Australia • Austria • Belgium • Brazil • Bulgaria • Canada • Chile • China PRC • Colombia • Costa Rica • Croatia • Cyprus
Czech Republic • Denmark • Dubai, UAE • Finland • France • Germany • Greece • Hong Kong SAR • Hungary • India • Indonesia • Ireland • Israel
Italy • Japan • Korea • Luxembourg • Malaysia • Mexico • The Netherlands • New Zealand • Norway • Peru • Philippines • Poland • Portugal
Puerto Rico • Romania • Russia • Saudi Arabia • Scotland • Singapore • Slovakia • Slovenia • South Africa • Spain • Sweden • Switzerland • Taiwan
Thailand • Turkey • Ukraine • United Kingdom • United States • Venezuela • Vietnam • Zimbabwe

Copyright © 2005 Cisco Systems, Inc. All rights reserved. CCSP, CCVP, the Cisco Square Bridge logo, Follow Me Browsing, and StackWise are trademarks of Cisco Systems, Inc.; Changing the Way We Work, Live, Play, and Learn, and iQuick Study are service marks of Cisco Systems, Inc.; and Access Registrar, Aironet, ASIST, BPX, Catalyst, CCDA, CCDP, CCIE, CCIP, CCNA, CCNP, Cisco, the Cisco Certified Internetwork Expert logo, Cisco IOS, Cisco Press, Cisco Systems, Cisco Systems Capital, the Cisco Systems logo, Cisco Unity, Empowering the Internet Generation, Enterprise/Solver, EtherChannel, EtherFast, EtherSwitch, Fast Step, FormShare, GigaDrive, GigaStack, HomeLink, Internet Quotient, IOS, IP/TV, iQ Expertise, the iQ logo, iQ Net Readiness Scorecard, LightStream, Linksys, MeetingPlace, MGX, the Networkers logo, Networking Academy, Network Registrar, Packet, PIX, Post-Routing, Pre-Routing, ProConnect, RateMUX, ScriptShare, SlideCast, SMARTnet, StrataView Plus, TeleRouter, The Fastest Way to Increase Your Internet Quotient, and TransPath are registered trademarks of Cisco Systems, Inc. and/or its affiliates in the United States and certain other countries.

All other trademarks mentioned in this document or Website are the property of their respective owners. The use of the word partner does not imply a partnership relationship between Cisco and any other company. (0502R) 205388.Y_ETMG_CC_9.05

